

CROSS ARM BRACES

High Density Apitong Cross Arm Braces

CMC's high density apitong wood cross arm braces are design engineered to support wood cross arms to provide durability, strength and extended service life. CMC's wood cross arm braces have better insulation properties than conductive metal braces.

Features:

- Lightweight alternative to steel cross arm braces.
- Corrosion resistant 6061-T6 aluminum end fittings.
- Tongue and groove configuration permanently pins end fitting to wood.
- Preservative treated, extra strong Apitong wood resists insect, fungus and environmental attack.
- Fittings are press-fit into the wood brace, eliminating the need for static-producing bolted ends. The added strength of the end fitting allows the use of smaller wood members, thereby reducing weight and producing a more eye-pleasing brace that is much stronger than one with bolted fittings.
- Reversible style eliminates need for left/right-hand braces.
- Sold in pairs.

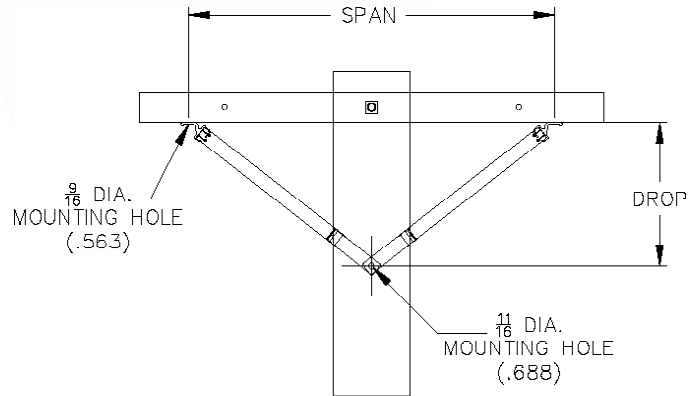
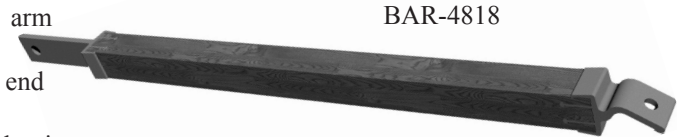

Slim Line Under Arm Braces: Apitong wood section 1-1/4" x 1 1/4"

CMC Cat. No.	Span Inches	Drop Inches	Length Hole to Hole	Weight/Pair (lbs)	Pole Mounting Hole	Cross arm Mounting Hole
BAF-4814	48	14	28	3.095	11/16"	9/16"
BAF-4818	48	18	30	2.710	11/16"	9/16"
BAF-4824	48	24	34	3.260	11/16"	9/16"
BAF-6018	60	18	35	3.530	11/16"	9/16"
BAF-6030	60	30	42	4.245	11/16"	9/16"
BAF-7222	72	22	42	8.00	11/16"	9/16"

Under Arm Braces: Apitong wood section 1-3/4"

CMC Cat .No. Under Arm	CMC Cat. No. Reversible Under Arm	Span Inches	Drop Inches	Length Hole to Hole	Weight/Pair (lbs)	Pole Mounting Hole	Cross arm Mounting Hole
BA-4814	BAR-4814	48	14	28	4.00	11/16"	9/16"
BA-4818	BAR-4818	48	18	30	5.248	11/16"	9/16"
BA-4824	BAR-4824	48	24	34	5.00	11/16"	9/16"
BA-6018	*BAR-6018	60	18	35	6.190	11/16"	9/16"
BA-6030	*BAR-6030	60	30	42	6.00	11/16"	9/16"
BA-7222	BAR-7222	72	22	42	7.91	11/16"	9/16"
BA-7236	BAR-7236	72	36	51	8.00	11/16"	9/16"

*RUS Approved

CROSS ARM BRACES

High Density Apitong Cross Arm Braces

CMC's high density apitong wood cross arm braces are design engineered to support wood cross arms to provide durability, strength and extended service life. CMC's wood cross arm braces have better insulation properties than conductive metal braces.

Features:

- Lightweight alternative to steel cross arm braces.
- Corrosion resistant 6061-T6 aluminum end fittings.
- Tongue and groove configuration permanently pins end fitting to wood.
- Preservative treated, extra strong Apitong wood resists insect, fungus and environmental attack.
- Reversible style eliminates need for left/right-hand braces.
- Fittings are press-fit into the wood brace, eliminating the need for static-producing bolted ends. The added strength of the end fitting allows the use of smaller wood members, thereby reducing weight and producing a more eye-pleasing brace that is much stronger than one with bolted fittings.
- Sold in pairs.

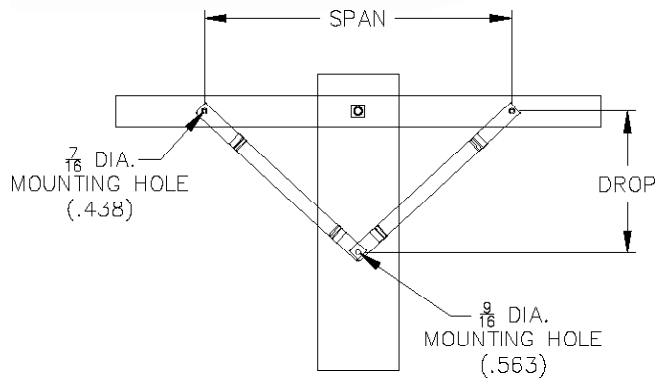

Flat Side-Arm Mount: Apitong wood section 13/16" x 1 3/4"

CMC Cat. No.	Span Inches	Drop Inches	Length Hole to Hole	Weight/Pair (lbs)	Pole Mounting Hole	Cross arm Mounting Hole
*BAB-626	38	17 3/4	26	2.215	9/16"	7/16"
**BAOB-626	38	17 3/4	26	2.360	9/16"	7/16"

*RUS Approved
 **Reverse Fitting

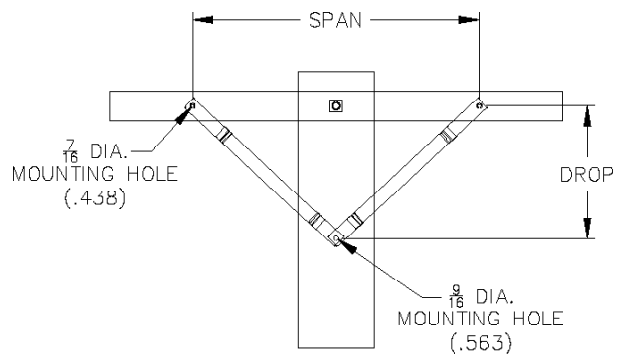

CROSS ARM BRACES

High Density Apitong Alley Arm Braces

CMC's high density apitong wood cross arm braces are design engineered to support wood cross arms to provide durability, strength and extended service life. CMC's wood cross arm braces have better insulation properties than conductive metal braces.

Features:

- Lightweight alternative to steel cross arm braces.
- Corrosion resistant 6061-T6 aluminum end fittings.
- Tongue and groove configuration permanently pins end fitting to wood.
- Preservative treated, extra strong Apitong wood resists insect, fungus and environmental attack.
- Fittings are press-fit into the wood brace, eliminating the need for static-producing bolted ends. The added strength of the end fitting allows the use of smaller wood members, thereby reducing weight and producing a more eye-pleasing brace that is much stronger than one with bolted fittings.
- Includes factory assembled lineman step.

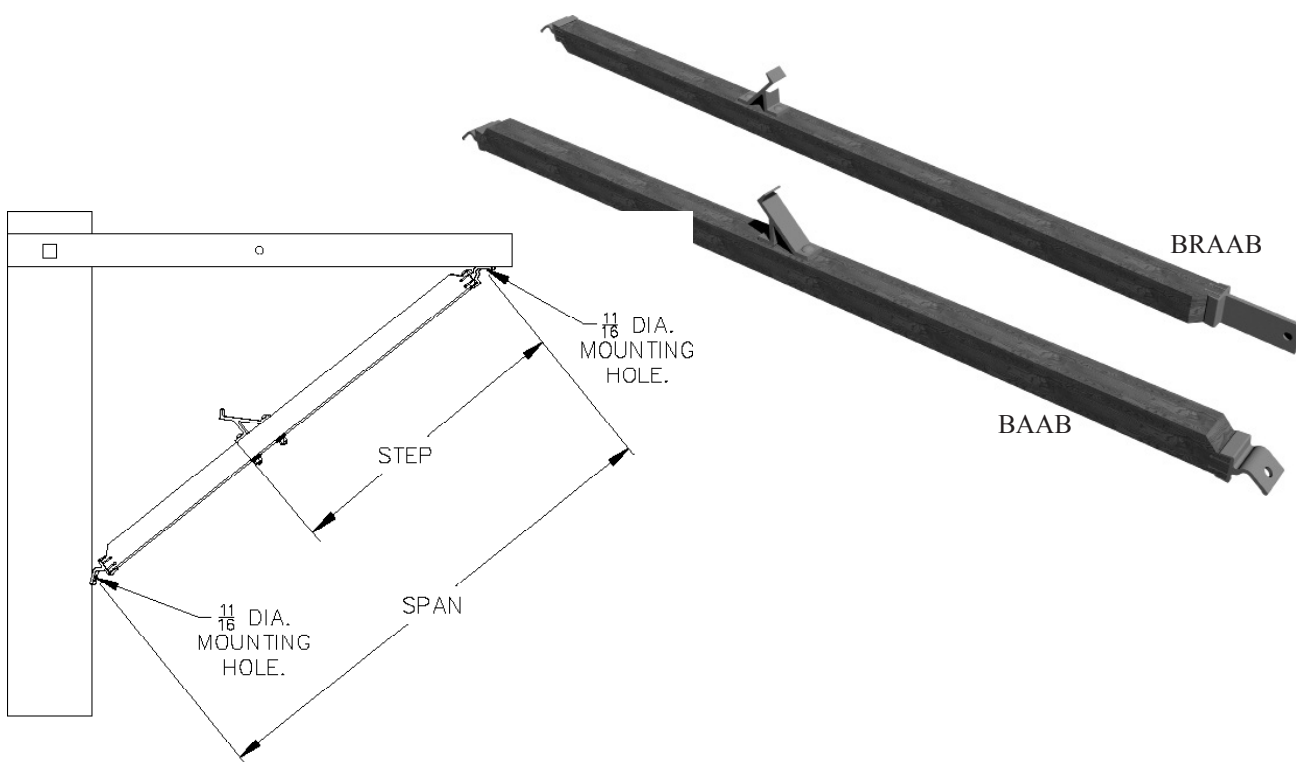

Alley Arm Braces: Apitong wood section 2 11/16" x 2 11/16"

CMC Cat. No.	Step Inches	Length Hole to Hole	Weight(lbs)	Pole Mounting Hole	Cross arm Mounting Hole
BAAB-60 or BRAAB-60	20 3/4	60	14.00	11/16"	11/16"
BAAB-76 or BRAAB-76	20 3/4	76	18.00	11/16"	11/16"
BAAB-84 or BRAAB-84	20 3/4	84	19.00	11/16"	11/16"
BAAB-120 or BRAAB-120	20 3/4	120	28.00	11/16"	11/16"

"R" indicates reversible style, eliminating the need for left/right hand braces.
For applications where step is NOT required, add suffix NS.

APITONG DEAD END ARM

High Density Two Position Dead End Arm

CMC's high density apitong wood dead end arms are design engineered to provide durability, strength and extended service life.

Features:

- Dead end arm supports are fully assembled
- Pre-drilled for dead end hardware and cross arm pins.
- Tongue and groove configuration permanently pins end fitting to wood.
- Preservative treated, extra strong Apitong wood resists insect, fungus and environmental attack.
- Fittings are press-fit into the wood brace, eliminating the need for static-producing bolted ends. The added strength of the end fitting allows the use of smaller wood members, thereby reducing weight and producing a more eye-pleasing brace that is much stronger than one with bolted fittings.

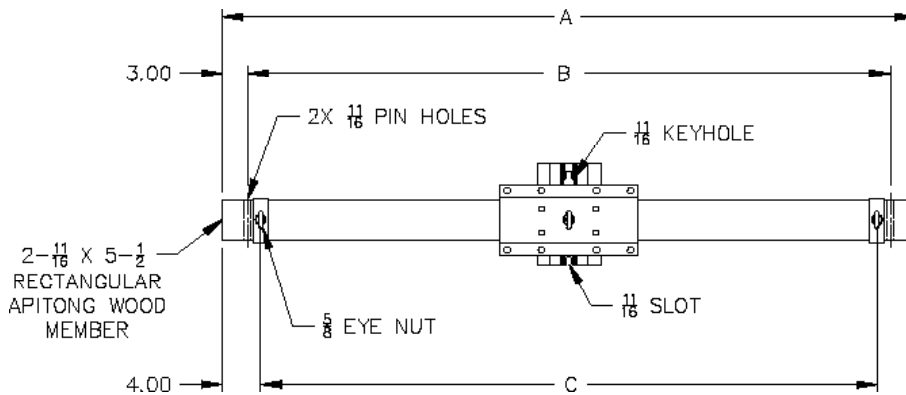
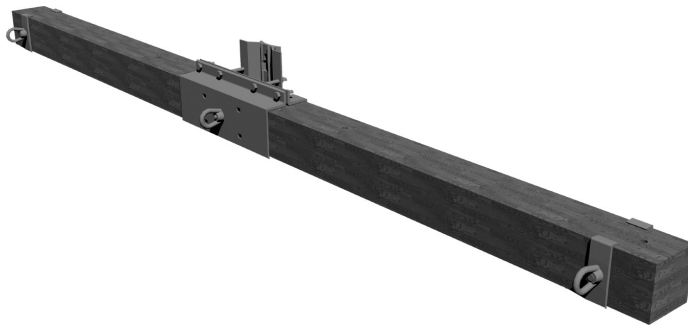

Dead End Arms: Apitong wood section 2 11/16" x 5 1/2"

CMC Cat. No.	A	B	C	Description	Weight/Single (lbs)
BDEA-36-EB	44"	33"	36"	36" dead end arm assembly	18.32
BDEA-48-EB	56"	50"	48"	48" dead end arm assembly	23.32
BDEA-60-EB	68"	62"	60"	60" dead end arm assembly	28.33

Standard package - 20 pieces